

INDUCTION RANGE

for residential use only



Models: **VDFSIE365..**

INSTALLATION INSTRUCTIONS

IMPORTANT - PLEASE READ AND FOLLOW

- Before beginning, please read these instructions completely and carefully.
- Do not remove permanently affixed labels, warnings, or plates from the product. This may void the warranty.
- Please observe all local and national codes and ordinances.
- Please ensure that this product is properly grounded.
- **The installer should leave these instructions with the consumer who should retain for local inspector's use and for future reference.**
- IN CANADA: The electrical plug should always be accessible.

Electrical installation must be in accordance with the National Electrical Code, ANSI/NFPA70 - latest edition and/or local codes.

IN CANADA: Electrical installation must be in accordance with the current CSA C22.1 Canadian Electrical Codes Part 1 and/or local codes.

Some models are supplied with a protective film on steel and aluminium parts. This film must be removed before installing/using the appliance.

THIS RANGE IS FOR RESIDENTIAL USE ONLY

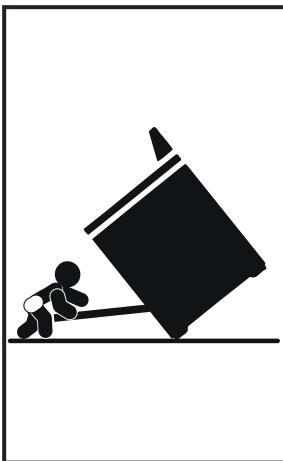

! WARNING

Tip-Over Hazard

A child or adult can tip the range and be killed. Check installation of anti-tip device per installation instructions.

Check engagement of anti-tip device if range is moved per installation.

Failure to follow these instructions can result in death or serious burns to children and adults.

See installation instructions for details.

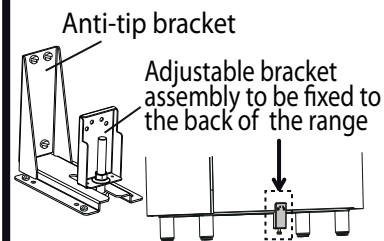

WARNING!!



Health Hazard

This appliance complies with electromagnetic safety standards.

However, persons with cardiac pacemakers or other electrical implants (such as insulin pumps) must consult with their doctor or implant manufacturer before using this appliance to make sure that their implants will not be affected by the electromagnetic field.

Failure to follow this advice may result in death.

Dear Customer,

Thank you for having purchased and given your preference to our product.

The safety precautions and recommendations reported below are for your own safety and that of others. They will also provide a means by which to make full use of the features offered by your appliance.

Please preserve this booklet carefully. It may be useful in future, either to yourself or to others in the event that doubts should arise relating to its operation.

This appliance must be used only for the task it has explicitly been designed for, that is for cooking foodstuffs. Any other form of usage is to be considered as inappropriate and therefore dangerous.

The manufacturer declines all responsibility in the event of damage caused by improper, incorrect or illogical use of the appliance.



WARNING: This product can expose you to chemicals including formaldehyde, which is known to the State of California to cause cancer, and lead, which is known to the State of California to cause birth defects or other reproductive harm. For more information go to [www. P65Warnings.ca.gov](http://www.P65Warnings.ca.gov).

This appliance is designed and manufactured solely for the cooking of domestic (household) food and is not suitable for any non-domestic application and therefore should not be used in a commercial environment.

The appliance warranty will be void if the appliance is used within a non-domestic environment i.e. a semi-commercial, commercial or communal environment.

USER INSTRUCTIONS

GENERAL INFORMATION

-  **WARNING!!**
This appliance shall not be used for space heating. This information is based on safety considerations.
- All openings in the wall behind the appliance and in the floor under the appliance shall be sealed.
- Keep appliance area clear and free from combustible materials, gasoline, and other flammable vapors.
- Do not obstruct the flow of ventilation air.
- Disconnect the electrical supply to the appliance before servicing.
- When removing appliance for cleaning and/or service;
 - Disconnect AC power supply.
 - Carefully remove the range by pulling outward.
CAUTION: Range is heavy; use care in handling.
- Electrical Requirement**
Electrical installation should comply with national and local codes.
- The misuse of oven door (e.g. stepping, sitting, or leaning on them) can result in potential hazards and/or injuries.
- When installing or removing the range for service, a rolling lift jack should be used. Do not push against any of the edges of the range in an attempt to slide it into or out of the installation. Pushing or pulling a range (rather than using a lift jack) also increases the possibility of bending the leg spindles or the internal coupling connectors.

WARNING!!

ELECTRICAL GROUNDING INSTRUCTIONS

The range must be electrically grounded in accordance with local codes or, in the absence of local codes, with the National Electrical Code, ANSI/NFPA No. 70-latest edition, in Canada Canadian Electrical Code.

Installation should be made by a licensed electrician.

FOR PERSONAL SAFETY, THIS APPLIANCE MUST BE PROPERLY GROUNDED.

If an external electrical source is utilized, the installation must be electrically grounded in accordance with local codes or, in the absence of local codes, with the national Electrical Code, ANSI/NFPA 70.

IN CANADA: This appliance is equipped with a four-prong grounding plug (NEMA 14-50P) for your protection against shock hazard and should be plugged directly into a properly grounded socket.

Do not under any circumstances cut or remove the fourth (ground) prong from the power plug.

REPLACEMENT PARTS

Only authorized replacement parts may be used in performing service on the range. Replacement parts are available from factory authorized parts distributors. Contact the nearest parts distributor in your area.

IMPORTANT PRECAUTIONS AND RECOMMENDATIONS

After having unpacked the appliance, check to ensure that it is not damaged.

In case of doubt, do not use it and consult your supplier or a professionally qualified technician.

Packing elements (i.e. plastic bags, polystyrene foam, nails, packing straps, etc.) should not be left around within easy reach of children, as these may cause serious injuries. The packaging material is recyclable and is marked with the recycling symbol .

- Do not attempt to modify the technical characteristics of the appliance as this may become dangerous to use.
- Do not carry out cleaning or maintenance operations on the appliance without having previously disconnected it from the electric power supply.
- After use, ensure that the knobs are in **Off** position.
- Do not allow children or other incapable people to use the appliance without supervision.
- During and after use of the range, certain parts will become very hot. Do not touch hot parts.
- Keep children away from the range when it is in use.
- Some models are supplied with a protective film on steel and aluminium parts. This film must be removed before installing/using the appliance.
- Fire risk!** Do not store flammable material in the oven and in the storage compartment.
- Make sure that electrical cables connecting other appliances in the proximity of the range cannot come into contact with the hob or become entrapped in the oven door.
- Do not line the oven walls with aluminium foil. Do not place shelves, broiler pan, pans or other cooking utensils on the base of the oven chamber.
- The manufacturer declines all liability for injury to persons or damage to property caused by incorrect or improper use of the appliance.
- To avoid any possible hazard, the appliance must be installed by qualified personnel only. Any repairs by unqualified persons may result in electric shock or short circuit. In order to avoid possible injuries to your body or to the appliance, do not attempt any repairs by yourself. Such work should be carried out by qualified service personnel only.

-
- **Danger of burns!** The oven and cooking accessories may become very hot during operation. Make sure children are kept out of reach and warn them accordingly. To avoid burns use kitchen clothes and gloves when handling hot parts or utensils.
 - Stand away from the range when opening oven door. Hot air or steam which escapes can cause burns to hands, face, and/or eyes.
 - Never clean the range, oven and storage compartment with a high-pressure steam cleaning device, as it may provoke a short circuit.
 - This appliance is intended for use in your household. Never use the appliance for any other purpose!
 - If you should decide not to use this appliance any longer (or decide to substitute an older model), before disposing of it, it is recommended that it be made inoperative in an appropriate manner in accordance to health and environmental protection regulations, ensuring in particular that all potentially hazardous parts be made harmless, especially in relation to children who could play with old appliances. Remove the door and the storage drawer before disposal to prevent entrapment.

IMPORTANT PRECAUTIONS AND RECOMMENDATIONS FOR USE OF ELECTRICAL APPLIANCES

Use of any electrical appliance implies the necessity to follow a series of fundamental rules.

In particular:

- Never touch the appliance with wet hands or feet.
- Do not operate the appliance barefooted.
- Do not allow children or disabled people to use the appliance without your supervision.

The manufacturer cannot be held responsible for any damages caused by improper, incorrect or unreasonable use of the appliance.

IMPORTANT PRECAUTIONS AND RECOMMENDATIONS FOR INDUCTION HOBS:

- Metallic objects such as knives, forks, spoons and lids should not be placed on the hob surface since they can get hot.
- Do not use metallic kitchen utensils (e.g. ladles). It is preferable to use plastic or wood kitchen utensils.
- Please use pans of recommended size (see minimum pan diameter recommended). It is not advisable to use pans smaller than the cooking zone. The pans have to be placed in the centre of the cooking zone.
- Do not use defective pans or pans with a curved bottom.
- Please use suitable pans marked for induction cooking.
- Please keep your distance from the electromagnetic fields by standing 5-10 cm from the cooking zones. When possible use the rear cooking zones.
- Magnetic objects (e.g. credit cards, floppy disks, memory cards) and electronic instruments (e.g. computers) should not be placed near the induction hob.
- The heating of magnetic tins is forbidden! Close tins may explode by exceeding pressure while heating. There is a burning risk with open tins as well, because the integrated temperature protection can't work well.

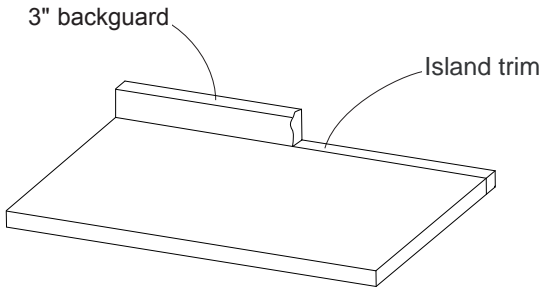

Fig. 1.1



INDUCTION COOKING HOB

- 1. Smart Zone 2100 W (3700 W *)
- 2. Double Zone, 7 1/8" / 10 1/4" (180/260mm) 1850/2600 W (3000/5500 W *)
- 3. Cooking zones display

* Maximum output when set on PowerBoost
 Smart Zone: PowerBoost is not available when cooking zones are bridged.

Attention: Disconnect the appliance from the mains if the ceramic hob is cracked and call the After Sales Service.

Metallic objects such as knives, forks, spoons and lids should not be placed on the hob surface since they can get hot.

Fig. 1.2

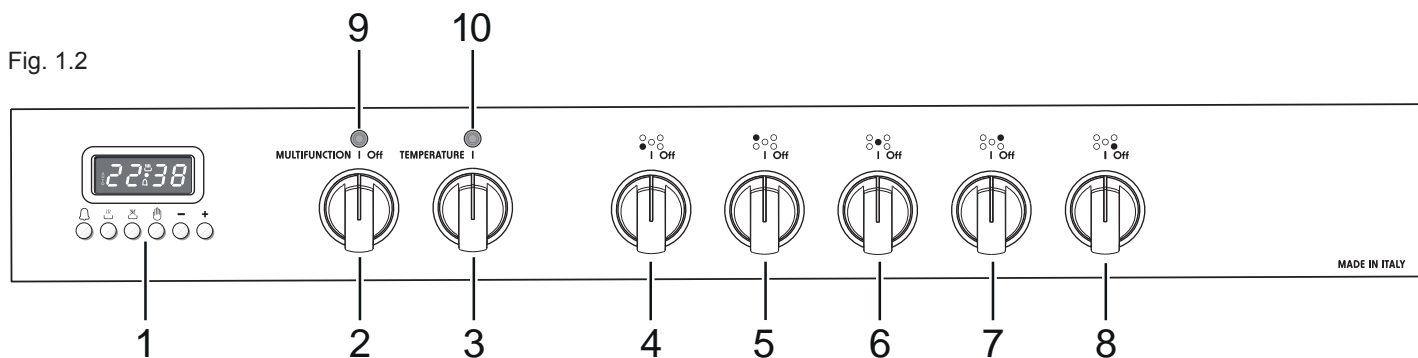

CONTROLS DESCRIPTION

1. Electronic programmer
2. Multifunction oven switch knob
3. Multifunction oven thermostat knob
4. Front left zone control knob
5. Rear left zone control knob
6. Central zone control knob
7. Rear right zone control knob
8. Front right zone control knob
9. Oven function indicator light
10. Oven thermostat indicator light

Please note: This appliance incorporates a safety cooling fan which you will hear operating whenever the oven or grill or induction hob are in use. This fan may continue to run for several minutes after the appliance has been switched off. This fan is to reduce the external temperature of the appliance and cool the internal components.

HOT SURFACE INDICATORS

When the temperature of a cooking zone is still hot, the relevant  remaining heat indicator lights up on the display to alert you of the hot surface.

Avoid touching the hob surface over the cooking area. Please pay special attention to children.

When the  is lit on the display, it is still possible to start cooking again; just turn the control knob to the required power level.

PAN DETECTION INDICATOR

If a display flashes  alternately with the heat setting, this means that:

- you have not placed a pan on the correct cooking zone or
- the pan you're using is not suitable for induction cooking or
- the pan is too small or not properly centred on the cooking zone.

No heating takes place unless there is a suitable pan on the cooking zone.

The cooktop will automatically turn off after 10 minutes if no suitable pan is placed on it.

Dual Zone: When using a small pot on the dual cooking zone, be sure to centre it so that the inner zone will detect the pan. If the pan covers the outer zone, then the outer zone will automatically switch on.

Smart Zones: The Smart Zones are large. You may place several small pots on the Smart Zone and they will be detected as if they were one large pot.

IMPORTANT! The whole of the Smart Zone is activated when a pot is detected. This means that other magnetizable items (such as cutlery) sitting in the cooking zone will heat up. Never leave cutlery or other magnetizable items on your cooktop.

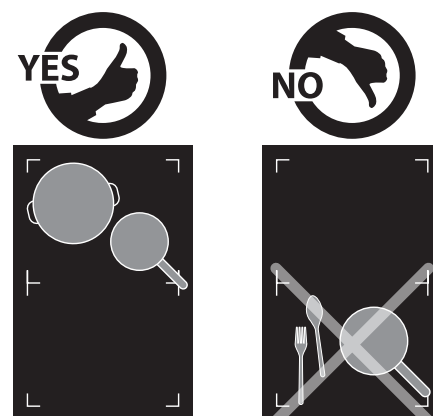

Fig. 2.2

COOKWARE FOR INDUCTION COOKING

The induction cooking system OPERATES ONLY if using correct cookware suitable for induction cooking.

The bottom of the pan has to be ferromagnetic to generate the electromagnetic field necessary for the heating process (meaning a magnet has to stick to the bottom of the pan).

Pans made from the following materials are not suitable:

- glass, wood, porcelain, ceramic, stoneware;
- pure stainless steel, aluminium or copper without magnetic bottom.

To check if a pan is suitable or not:

- test the bottom of the pan with a magnet: if the magnet sticks, the pan is suitable.
- if a magnet is not available pour a small amount of water inside the pan and place the pan on a cooking zone. Switch on the cooking zone: if the symbol  (pan detection) appears on the cooking zone display (alternately with the heat setting), the pan is not suitable.

Quality of cookware - IMPORTANT!

- The quality of your cookware can affect cooking performance. Only use induction-compatible cookware that has been specifically designed for induction cooking. Look for the induction symbol on the packaging or the bottom of the pan.
- Cookware that has a high content of ferromagnetic material that continues up from the base into the sides of the pan will give the best cooking performance.

Quickest heating performance: High content of ferromagnetic material. Heating area is consistent across the base and continues up the sides of pan.

Average heating performance: Reduced area of ferromagnetic material. Reduced zone of heating, results in poor cooking performance and slower heating.

Slow heating performance: Very limited area of ferromagnetic material. Results in very slow heating performance. Note: this type of pot is good for very delicate tasks such as melting chocolate, as heating is very slow.

Important note: the cooking zones will not operate if the pan diameter is too small ( pan detection symbol will appear on the cooking zone display, alternately with the heat setting). To correctly use the cooking zones follow the indications given in the following table.

Induction cooking zone	Minimum pan diameter recommended
Double Zone	5" (125mm) (inner zone) 9 7/8" (250mm) (dual zone)
Smart Zones	5 11/16" (145mm) (un-bridged) 9 5/8" (245mm) (bridged)

Always use pans with thick, completely flat bottom.

Do not use pans with concave or convex bottom; these could cause overheating of the cooking zone.

Notes:

- Some types of pans could cause noise when used on an induction cooking zone. The noise does not mean any failure on the appliance and does not influence the cooking operation.
- It is normal if the cooktop makes a low humming noise when used on a high heat setting (especially "PowerBoost"), this is caused by the technology of induction cooking, but the noise should quieten down or disappear completely when you decrease the heat setting.

CONTROL KNOBS

Each cooking zone is adjusted by a separate control knob positioned on the control panel and the operation is controlled by the electronic system.

If a cooking zone is not turned Off the electronic system automatically switches it Off after a pre-set time which depends on the power setting.

POWER LEVEL

Push and turn the knob clockwise to set the desired power level between  Gentle Heat low setting (minimum) and "9" (maximum).

The power level can be modified at any time by turning the knob clockwise or anti-clockwise to a different setting.

The cooking zone display shows the selected level.

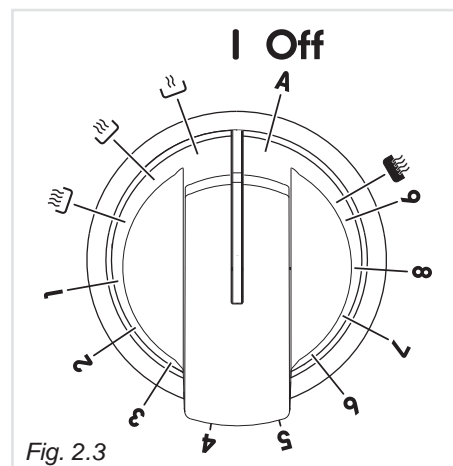





Fig. 2.3

EXAMPLES OF COOKING POWER SETTING		
OFF	Zone Off	Cooking zone not operating
	Gentle Heat low	Melting chocolate, butter, and foods that burn quickly
	Gentle Heat medium	Delicate warming for small amounts of food
	Gentle Heat simmer	Simmering soups, stocks and sauces
1 to 2	Melting Reheating	Sauces, butter, chocolate, gelatine Dishes prepared beforehand
2 to 3	Simmering Defrosting	Rice, pudding, sugar syrup Dried vegetables, fish, frozen products
3 to 4	Steam	Vegetables, fish, meat
4 to 5	Water	Steamed potatoes, soups, pasta, fresh vegetables
6 to 7	Medium cooking Simmering	Meat, lever, eggs, sausages Goulash, roulade, tripe
7 to 8	Cooking	Potatoes, fritters, wafers
9	Frying, roasting Boiling water	Steaks, omelettes, fried dishes Water
	Boiling water	-

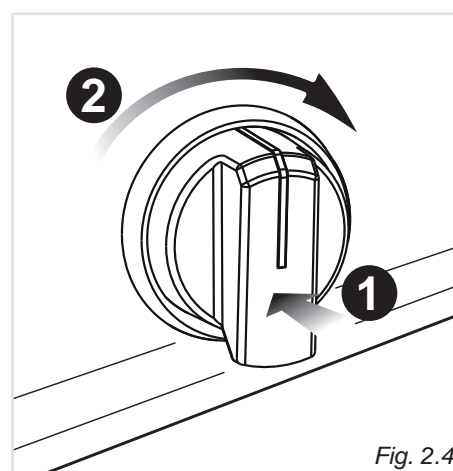





Fig. 2.4

OPERATION TIME LIMIT OF COOKING ZONES

Each cooking zone is automatically switched Off after a maximum preset time if no operation is performed.

The maximum preset time limit depends on the set power level, as illustrated in this schedule.

Each operation on the cooking hob by using the knob will reset the maximum operation time at its initial value.

Power level of Cooking zones	Operation time limit
 ,  or 	2 hours
1	6 hours
2	6 hours
3	5 hours
4	5 hours
5	4 hours
6	1.5 hours
7	1.5 hours
8	1.5 hours
9	1.5 hours
	10 minutes
A	See the "FAST HEATING" FUNCTION section

GENTLE HEAT

Gentle Heat settings:

- The Low setting is ideal for the most delicate cooking tasks (such as melting chocolate), as the cooking zone will provide a very low continuous gentle heat.
- The Medium setting is ideal for keeping cooked food warm and the gentle warming of delicate foods.
- The Simmer setting is ideal for extended cooking of soups, stocks and sauces.

To set a cooking zone for Gentle Heat:

Push and turn the dial to either , or . The display will show , or .

“FAST HEATING” FUNCTION

This function allows the cooking zone to operate at the maximum power (100%) for a time proportional to the selected power level (“1” ÷ “8” only); after this time the cooking zone will operate at the selected level.

This function is available on all the cooking zones.

This feature lets you rapidly heat up food or liquid then automatically reduce the temperature to a pre-selected heat setting.

To set a cooking zone for the “Fast Heating” function:

1. Press in and turn the control dial counterclockwise to **A**. Hold the dial at **A** until appears in the cooking zone display.
2. Turn the control dial (within 5 seconds) to the desired heat setting (“1” ÷ “8”). The heat setting and will alternate in the display. The “Fast Heating” function is now set.

During rapid heat will flash alternately with the heat setting you have selected.

When rapid heat is finished will stop flashing and the temperature will automatically reduce to the heat setting you have selected.

The amount of time the cooking zone will rapidly heat for depends on the heat setting you have selected. See below chart for rapid heat times.

To cancel the “Fast Heating” function (while is still flashing):

- Turn the control dial to a lower heat setting or back to “OFF”.
- Increasing the heat setting to “9” will also cancel the “Fast Heating”.

Note: The “Fast Heating” and “PowerBoost” features cannot be used together. If you turn “PowerBoost” on when “Fast Heating” is already set, the “Fast Heating” function will be cancelled.

SELECTED HEAT SETTING	APPROXIMATE TIME AT “FAST HEATING”
1	48 seconds
2	144 seconds
3	230 seconds
4	312 seconds
5	408 seconds
6	120 seconds
7	168 seconds
8	216 seconds

“POWERBOOST” FUNCTION

To set a cooking zone for “PowerBoost”:

1. Press and turn the cooking zone on to its highest heat setting (“9”).
2. From heat setting “9”, turn and hold the dial to until appears in the display.

The “PowerBoost” program is now operative.

This function allows the cooking zone to operate at the “PowerBoost” maximum power (above the nominal power) for maximum 10 minutes; it could be used, for example, to rapidly heat up large amount of water.

To disable this function turn the knob anti-clockwise to a lower power level or to the “OFF”.

IMPORTANT:

- You can set three cooking zones for “PowerBoost” at the same time as long as one is not behind the other.
- It is not possible to set all the cooking zones for “PowerBoost” at the same time.
- If one cooking zone is set to “PowerBoost” and you accidentally also set a second cooking zone immediately in front or behind to “PowerBoost”, the first cooking zone will warn you that the configuration is not possible, flash and then automatically reduce its power level.
- When a cooking zone is set for “PowerBoost”, the cooking zone immediately in front of or behind may automatically reduce its power level.
- “PowerBoost” is not available if cooking zones are bridged.
- If a cooking zone is still hot, it is not possible to use the “PowerBoost” function and will flash if you try to activate. Allow the cooktop to cool down.

IMPORTANT NOTES:

- The “PowerBoost” function is not suitable for use with non water based cooking. Do not use this function for heating oil (e.g. deep fat frying).
- “PowerBoost” heats food and liquids very quickly. Do not leave the cooktop unattended when using this feature.

Fig. 2.5

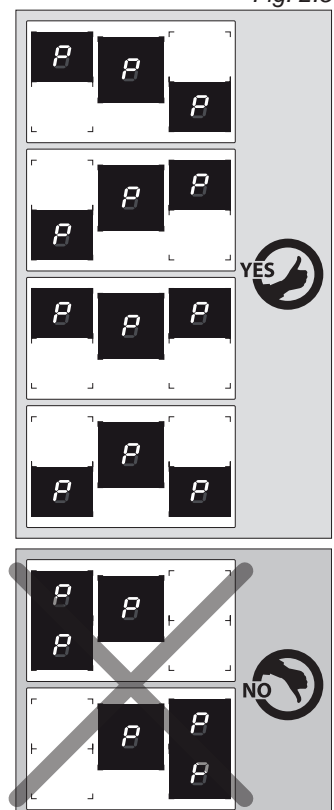

BRIDGING SMART ZONES

- The bridging zone function allows you to use two Smart Zones together giving you a larger cooking area. Your pan(s) will need to cover both cooking zones.
- There may be a cooler area in the centre of the cooktop between the bridged cooking zones. You may need to move food around the pan to ensure even cooking.
- When using bridging zones it is not possible to use the “PowerBoost” function.

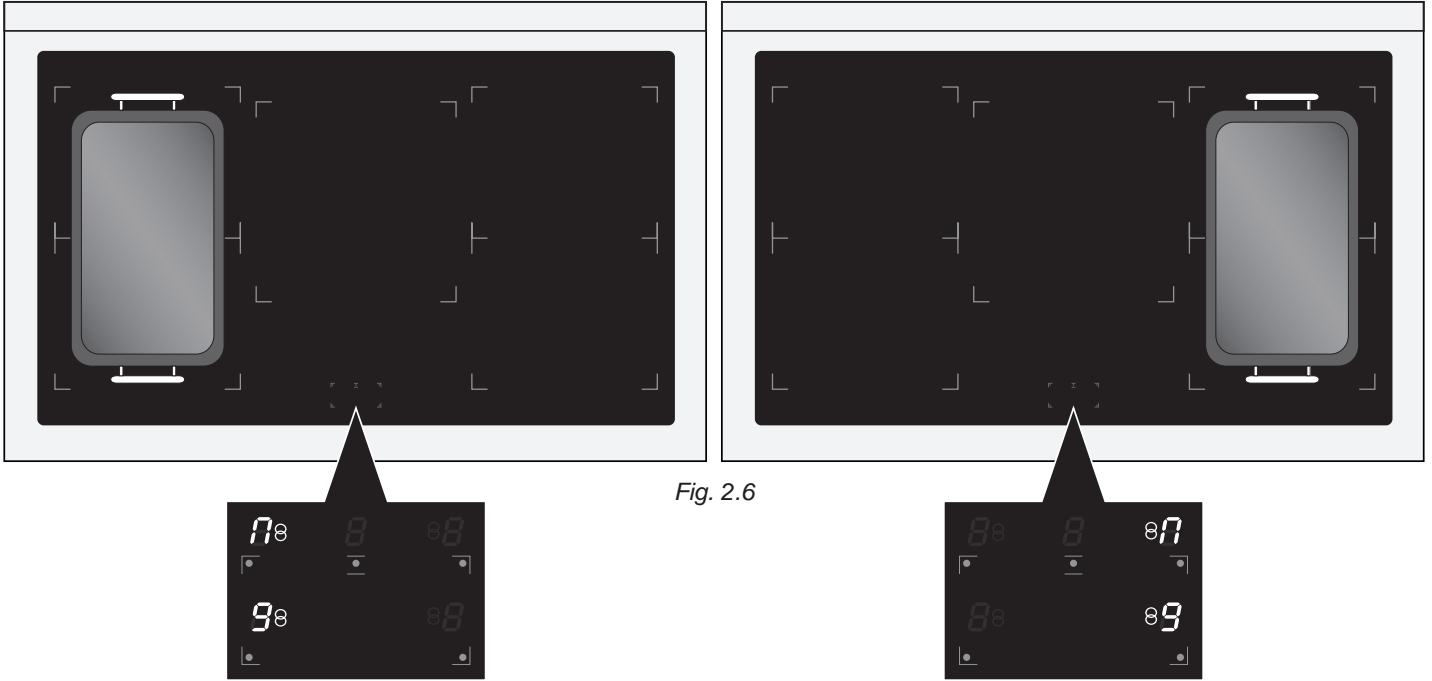

Fig. 2.6

To select the bridging function:

1. Place the pan on the cooktop over the two zones you wish to use, covering both cooking zones (as shown above).
2. Push in and turn both control dials for the selected cooking zones clockwise to the highest heat setting “9”.
3. Turn both dials to and hold until appears in the cooking zone displays.
The front cooking zone display will show the heat setting. The rear cooking zone display will show .
4. Use the front cooking zone control dial to adjust the heat setting for the bridged zone (“1” ÷ “9”).
Adjusting the rear cooking zone will cancel bridging.

If no pan is detected

- If no pan is detected on either cooking zone, the front cooking zone display will alternate between the selected setting and . The rear cooking display will show .
- If no pan is detected on one cooking zone:
The front cooking zone display will still show the selected heat setting and the rear cooking zone display will still show .
If after 10 minutes no pan is detected:
 - the bridging function will switch off;
 - the cooking zone without a detectable pan will continue to show ;
 - the remaining cooking zone will continue cooking at the selected heat setting.

Using the “Fast heating” function in bridged mode

1. Bridge the cooking zones.
2. Turn the control dial for the front cooking zone back past “OFF” to **A**. Hold the dial at **A** until starts alternating in the display.
3. Turn the control dial to your selected heat setting. The heat setting and will alternate in the display.
4. The bridged zone is now set for “Fast heating”.

To cancel bridging

Turn both control dials back to “OFF”.

CHILDLOCK SAFETY (LOCKING THE COOKTOP)

When not using the induction cooktop, set the childlock safety to prevent children from accidentally switching on the cooking zones (or for cleaning and to prevent unintended use).

When the cooktop is locked the controls and cooktop display will remain unresponsive.

Ensure all cooking zones are switched "OFF", then turn counterclockwise at the same time the control knobs of the two left cooking zones (**A** setting) and hold the knobs in this position until **L** lights up on the cooking zones display; then release the knobs.

To deactivate the childlock repeat the same procedure until **L** lights up on the cooking zones display; then release the knobs.

THERMAL PROTECTIONS

The induction cooktop is fitted with safety devices to protect the electronic system and to protect each cooking zone from overheating. In case of overheating, one of the following automatic functions could be started by the electronic system:

- "PowerBoost" program deleted and power reduced;
- power reduced;
- one or more cooking zones switched Off;
- cooling fan motor of the induction unit switched on (it may continue to run even after you've turned the cooktop off. Do not switch the power to the range off at the wall while the fan is running).

MAXIMUM USABLE POWER FOR THE COOKING ZONES

The left/central and right cooking zones are controlled by two separate power boards (see figure below) with the following maximum total power:

- 1st power board (left/central zones): 7400 W;
- 2nd power board (right zones): 3700 W.

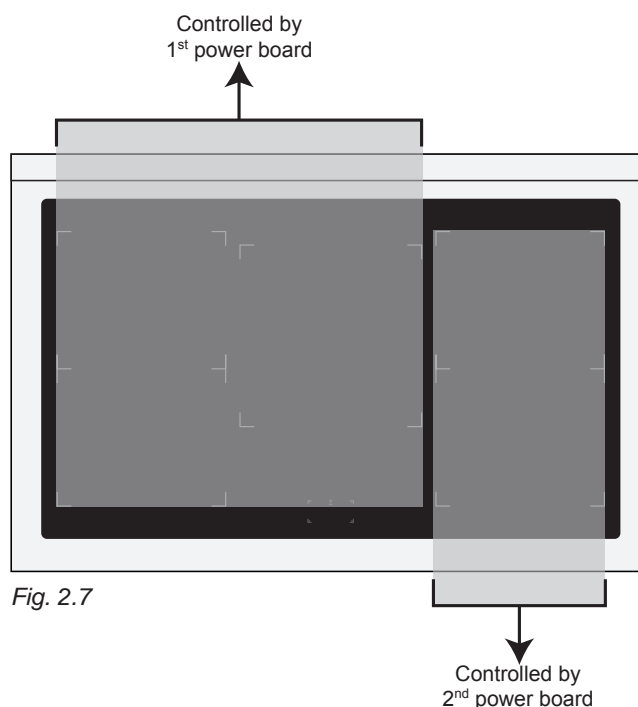

Should the cooking zones of one power board require more than the maximum total power, the last selected power level has priority and the power of the other cooking zone(s) is automatically reduced to the remaining power available (or switched off if there is not enough power available).

If this occurs, the cooking zone(s) will display a flashing figure for about 3 seconds before automatically displaying the new power level.

This means for example that:

- When setting a "PowerBoost" programme for the second (or third) zone, the setting for the other zone(s) could be reduced to the remaining power available.
- When setting a "PowerBoost" programme for a zone and then another setting on the second zone (and on third zone), if the total power exceed the maximum total power, the "PowerBoost" programme is deleted and the power reduced to the maximum power available.

ADVICE FOR SAFE USE OF THE HOB

- Before switching on make sure that you have the correct knob for the hotplate chosen. It is advisable to put the pan on the hotplate before switching on and to take it away after switching off.
- Use cookware with flat and even bottoms. Uneven bottoms can scratch the glass ceramic surfaces. Be careful that the bottom is clean and dry.
- Always lift pans off the cooktop – do not slide, or they may scratch the glass.
- Do not leave wet or damp lids on the hob.
- The glass-ceramic surface and pans must be clean. Carefully eliminate any food remains (especially containing sugar), dirt etc. with the aid of a cleansing agent.
- Make sure that the handles of cookware do not stick out over the edge of the cooker, to avoid them being knocked over by accident. **This also makes it more difficult for children to reach the cooking vessels.**
- Do not lean over the cooking zones when they are switched on.
- Do not drop heavy or sharp objects on the glass ceramic cooktop. **If the glass surface is broken or damaged, disconnect the appliance from the electrical mains supply and contact the after-sales service.**
- Do not put aluminium foil or plastic objects on the cooking zones when they are hot.
- Follow the cleaning instructions carefully.

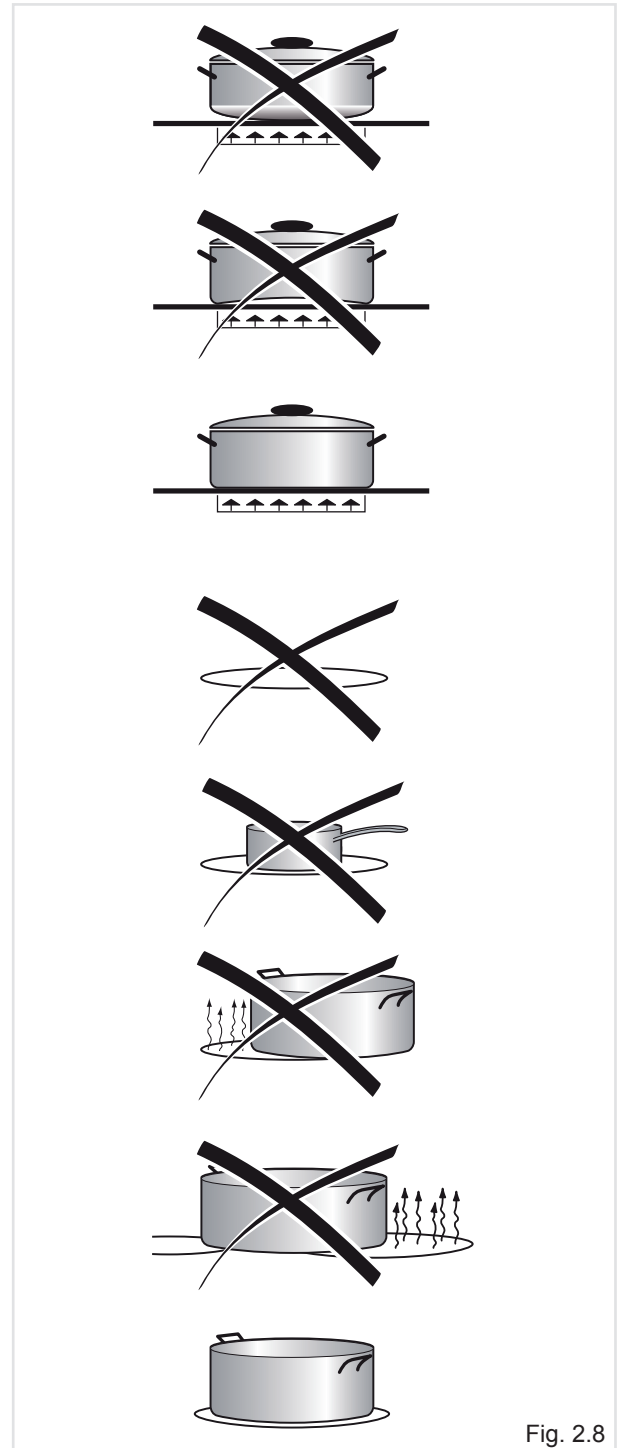

Fig. 2.8

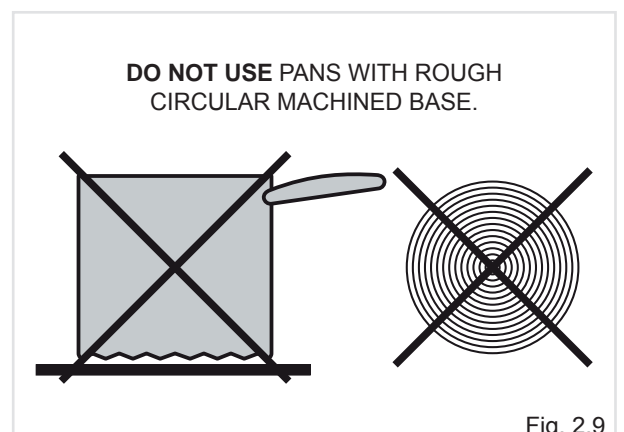

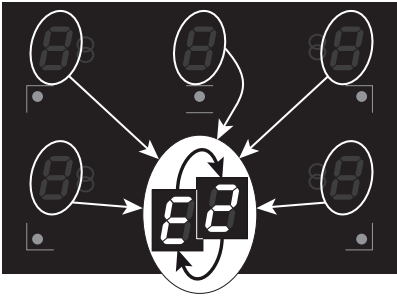

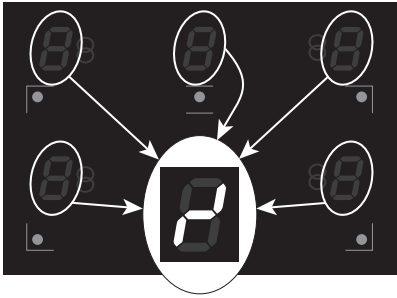

Fig. 2.9

ERROR CODES ON THE COOKING ZONES DISPLAY

Error code	Example	What to do
<p>Erxx (e.g. Er20, Er21, Er22, Er31, Er36, Er40, Er47, ...)</p> <p>or</p> <p>display not operative</p>		<ol style="list-style-type: none"> For error “Er21” only: first, let the appliance cool down completely. For all “Erxx” errors: switch off the cooker and disconnect it from the mains. Wait for about 1 minute, then reconnect the cooker and turn on the cooking zones. Wait for about 1 minute and if the error message does not appear again the cooking zones can be used. If the problem continues do not use the induction hob (only use the oven) and contact your Authorised Service Centre. Please note down the error letters and numbers, the error code information is important for the Service.
<p>Ex (e.g. EA, E2, E3, E4, E5, E6, E7, E8, E9, ...)</p> <p>“E” and “x” alternating for one or more cooking zones.</p>		<p>For error “E2”: this indicates an overheating of the cooking zone/s.</p> <ol style="list-style-type: none"> Switch off the cooking zone/s and leave to cool. If the problem continues do not use the induction hob (only use the oven) and contact your Authorised Service Centre. Please note down the error letter and number, the error code information is important for the Service. <p>For the other errors:</p> <ol style="list-style-type: none"> Switch off the cooker and disconnect it from the mains. Wait about 1 minute, then reconnect the cooker and turn on the cooking zones. Wait for about 1 minute and if the error message does not appear again, the cooking zone can be used. If the problem continues, make a note of the error code, switch off the appliance and contact your Authorised Service Centre. Please note down the error letter and number, the error code information is important for the Service.
<p>U400</p>		<p>This indicates an over-voltage on power supply.</p> <ol style="list-style-type: none"> Switch off the cooker and disconnect it from the mains. Check the correct power voltage is available in the domestic electrical system as indicated in the appliance rating label.
<p>Symbol as per side figure</p>		<p>This indicates an incorrect operation of one or more cooking zone control knob.</p> <ol style="list-style-type: none"> Turn the cooking zone control knobs to the “OFF” position, then switch off the cooker and disconnect it from the mains. Wait for about 1 minute, then reconnect the cooker and turn on the cooking zones. Wait for about 1 minute and if the error message does not appear again the cooking zones can be used. If the error message does not disappear repeat step from 1 to 3. If the problem continues do not use the induction hob (only use the oven) and contact your Authorised Service Centre. Please note down the error, the error code information is important for the Service.

GENERAL FEATURES

As its name indicates, this is an oven that presents particular features from an operational point of view.

In fact, it is possible to insert 7 different programs to satisfy every cooking need.

The 7 positions, thermostatically controlled, are obtained by 4 heating elements which are:

- Lower heating element
- Upper heating element
- Broil heating element
- Circular heating element

ATTENTION: the range becomes very hot during operation.

ATTENTION: the oven door becomes very hot during operation.

KEEP CHILDREN AWAY.

WARNING:

The door is hot, use the handle.

USING THE OVEN FOR THE FIRST TIME







- Put in the shelf and the tray.
- Switch the oven on empty (on a cooking function) at maximum power for about 2 hours to remove traces of grease and smells from the components.
There will be a distinctive smell and a small amount of smoke during the conditioning process as manufacturing residue is burnt off. This is normal, but make sure the kitchen is well ventilated during the conditioning.
- When the oven has cooled down and unplugging the range, clean the inside of the oven with a cloth soaked in water and neutral detergent and dry it perfectly.

VERY IMPORTANT

The oven shall be used always with the door closed.

OPERATING PRINCIPLES

Heating and cooking in the multifunction oven takes place as follows:

- **by normal convection** -  The heat is produced by the upper and lower heating elements.
- **by forced convection** -  The heat produced by the circular element is distributed throughout the oven by the fan.
- **by semi-forced convection** -  The heat produced by the upper and lower heating elements is distributed throughout the oven by the fan.
- **by radiation** -  The heat is radiated by the infra red broil element.
- **by radiation and fan** -  The radiated heat from the infra red broil element is distributed throughout the oven by the fan.
- **by semi-forced convection from the top** -  The heat produced by the upper heating element is distributed throughout the oven by the fan.
- **by ventilation** -  The food is defrosted by using the fan only function without heat.

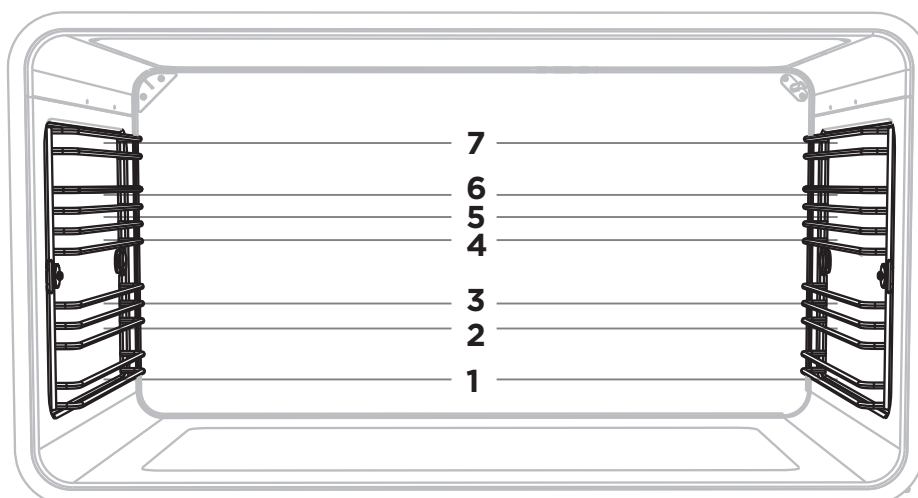

Fig. 3.1

THERMOSTAT KNOB (fig. 3.2)

To turn on the heating elements of the oven, set the switch knob on the desired program and the thermostat knob onto the desired temperature.

To set the temperature, it is necessary to make the chosen number, printed on the knob, to match with the control panel indicator.

The elements will turn ON or OFF automatically according to the energy need which is determined by the thermostat.

The indicator light will cycle on and off during cooking.

TEMPERATURE I

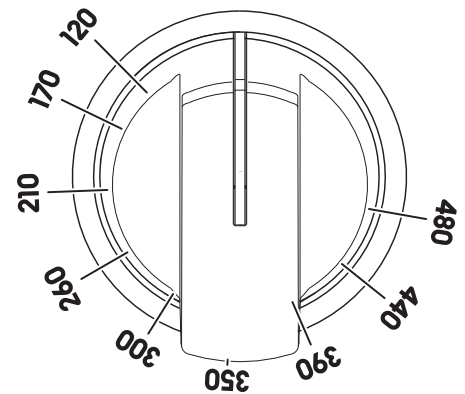

Fig. 3.2

FUNCTION SELECTOR KNOB (fig. 3.3)

VERY IMPORTANT: ALWAYS LIGHTLY PRESS THE CONTROL KNOB WHEN TURNING THE FUNCTION KNOB FROM THE OFF POSITION (fig. 3.4).

Rotate the knob clockwise to set the oven to one of the following functions:

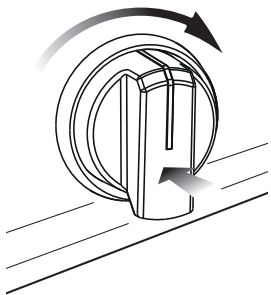

Fig. 3.4

MULTIFUNCTION I Off

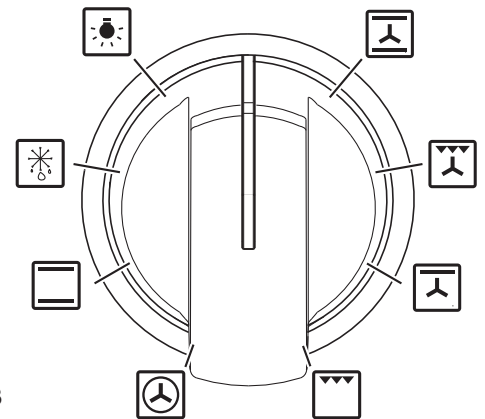

Fig. 3.3



OVEN LIGHT (this is not a cooking function)

Turning the knob to this position, only the oven lamp lights up. The lamp is always on in all the cooking functions.



DEFROSTING FROZEN FOODS (this is not a cooking function)

Only the fan and the oven lamp switch on. To be used with the thermostat knob on **Off** because the other positions have no effect. Defrosting takes place by fan, without heating.

Recommended for:

To rapidly defrost frozen foods; 2.2 lbs (1 kg) requires about one hour. The defrosting times vary according to the quantity and type of foods to be defrosted.



TRADITIONAL CONVECTION COOKING

The upper and lower heating elements switch on. The heat is diffused by natural convection and the temperature must be set between 120 °F (50 °C) and 480 °F (250 °C) via the thermostat knob.

Recommended for:

For foods which require the same cooking temperature both internally and externally, i. e. roasts, spare ribs, etc.



VENTILATED COOKING

The circular element and fan come on.

The heat is dispersed by forced convection and the temperature can be regulated to between 120 °F (50 °C) and 480 °F (250 °C) via the thermostat knob. The oven does not require preheating.

Recommended for:

Food which has to be well-cooked outside and soft or rosy inside, for example lasagne, lamb, roast beef, whole fish etc.



BROILING

The infrared heating element switches on.

The heat is diffused by radiation. The temperature can be set between 120 °F (50 °C) and 480 °F (250 °C) via the thermostat knob.

For correct use see the "BROILING" section.

Recommended for:

Intense broiling action for cooking with the broiler; browning, crisping, toasting, etc.



MAINTAINING TEMPERATURE AFTER COOKING OR SLOWLY HEATING FOODS

The upper element and the fan are on. The heat is diffused by forced convection with the most heat being produced by the upper element. The temperature must be regulated between 120 °F (50 °C) and 480 °F (250 °C) via the thermostat knob.

Recommended for:

To keep foods hot after cooking. To slowly heat already cooked foods.



VENTILATED BROILING

The infrared heating element and the fan switch on. The heat is mainly diffused by radiation and the fan distributes it in the whole oven.

The temperature can be set between 120 °F (50 °C) and 480 °F (250 °C) via the thermostat knob.

For correct use see the "VENTILATED BROILING" section.

Recommended for:

For grill cooking when a fast outside browning is necessary to keep the juices in, i. e. veal steak, steak, hamburger, etc.



CONVECTION COOKING WITH VENTILATION

The upper and lower heating elements and the fan turn on.

The heat is dispersed by forced convection and the temperature can be regulated to between 120 °F (50 °C) and 480 °F (250 °C) via the thermostat knob.



Recommended for:

For foods of large volume and quantity which require the same internal and external degree of cooking; for ie: rolled roasts, turkey, legs, cakes, etc.

COOKING ADVICE

STERILIZATION

Sterilization of foods to be conserved, in full and hermetically sealed jars, is done in the following way:

- Turn the switch to position  or .
- Set the thermostat knob to position 350 °F (175 °C) and preheat the oven.
- Fill the grill pan with hot water.
- Set the jars into the grill pan making sure they do not touch each other and the door and set the thermostat knob to position 260 °F (130 °C).

When sterilization has begun, that is, when the contents of the jars start to bubble, turn off the oven and let cool.

REGENERATION

Turn the switch to position  or  and set the temperature to 300 °F (150 °C).



Bread becomes fragrant again if wet with a few drops of water and put into the oven for about 10 minutes.

ROASTING

To obtain classical roasting, it is necessary to remember:

- the pre-set temperature should be maintained.
- that the cooking time depends on the quantity and the type of foods.

COOKING DIFFERENT DISHES AT THE SAME TIME

The MULTIFUNCTION oven at positions  or  of the function selector can cook various different foods at the same time. Fish, cakes and meat can be cooked together without the smells and flavours mixing.

The only precautions required are the following:

- The cooking temperatures must be as close as possible with a maximum difference of 70-80 °F (20-25 °C) between the different foods.
- Different dishes must be placed in the oven at different times according to the cooking time required for each one. This type of cooking obviously provides a considerable saving on time and energy.

VENTILATED BROILING

Ventilated broiling may be done by selecting  with the function selector knob; the hot air completely envelops the food that is to be cooked.

Introduce the food to be cooked, positioning the grill pan as close to the infra-red element as possible.

Close the door and let the oven operate until broiling is done.

Adding a few dabs of butter before the end of the cooking time gives the golden "au gratin" effect.

Broiling with the oven door closed.

Important: Use always suitable protective gloves when inserting/removing the broiling pan from the oven (see next page).



WARNING!!

**WARNING
VERY IMPORTANT**

**It is advisable to handle
the oven accessories
using oven gloves.**

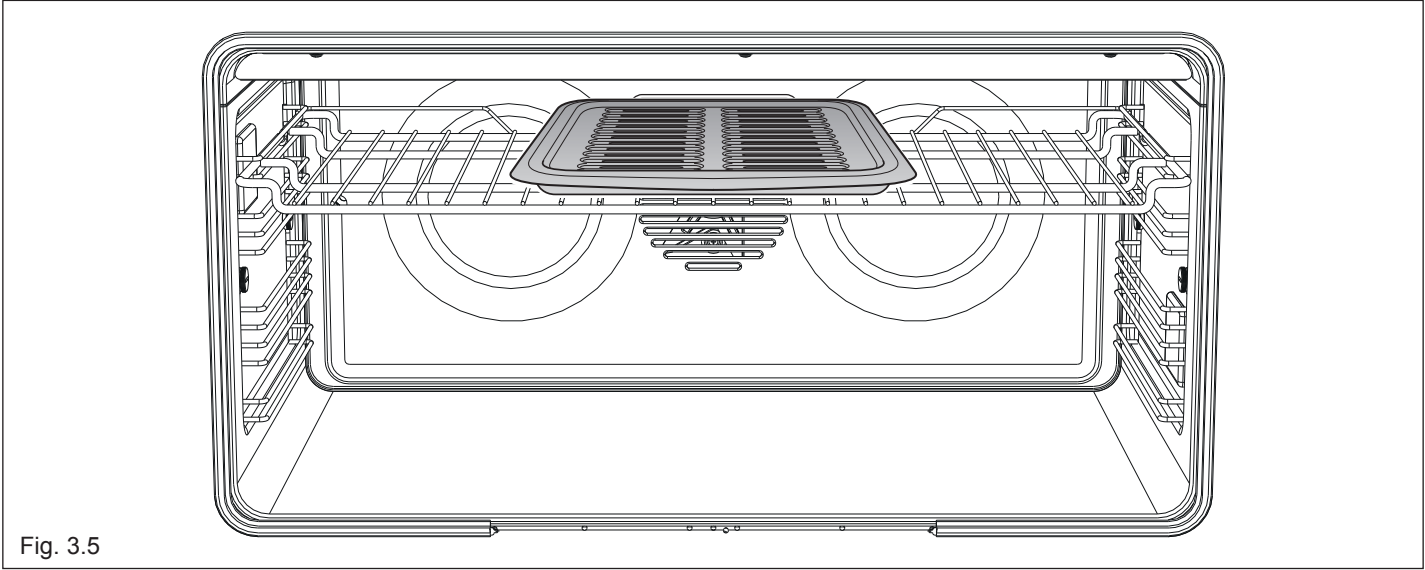

Fig. 3.5

BROILING

Very important: the broil burner must always be used with the oven door closed.

- Position the shelf on the first level from the top (fig. 3.5).
- Turn on the broil burner, as explained in the preceding paragraphs and let the broil burner preheat for about 5 minutes with the door closed.
- Place the food to be cooked above the broiling pan.
- Introduce the broiling pan in the oven (fig. 3.8). The broiling pan should be placed above the shelf and it should be centered with the broil burner (fig. 3.5).

Do not broil without using the broiling pan.

Important: Use always suitable protective gloves when inserting/removing the broiling pan, shelves, pans or other cooking utensils from the oven.

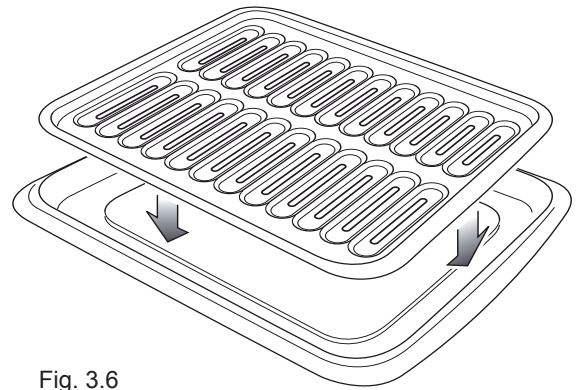

Fig. 3.6

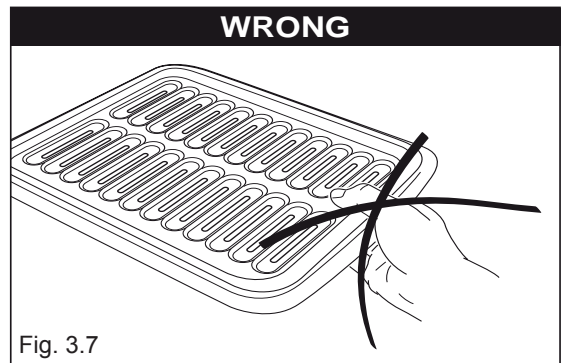

Fig. 3.7

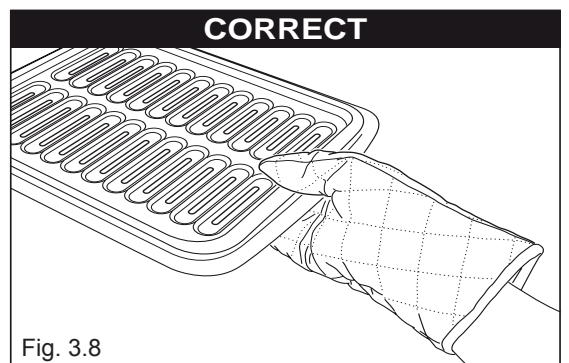







Fig. 3.8



The electronic programmer is a device which groups together the following functions:

- 12 hours clock with illuminated display
- Timer (up to 23 hours and 59 minutes)
- Program for automatic oven cooking
- Program for semi-automatic oven cooking

Description of the buttons:

-  Timer
-  Cooking time
-  End of cooking time
-  Manual position and cancellation of the inserted cooking program
-  To increase the numbers on the digital display
-  To decrease the numbers on the digital display.

Description of the illuminated symbols:

- AUTO** flashing - Programmer in automatic position but not programmed
- AUTO** always lighted - Programmer in automatic position with programme inserted.
-  Automatic cooking taking place or oven in manual mode.
-  Timer in operation
-  and **AUTO** - flashing - Programme error.
(The time of day lies between the calculated cooking start and end time).

Note: Select a function by the respective button and, in 5 seconds, set the required time with the **+** / **-** buttons (“one-hand” operation).

A power cut zeroes the clock and cancels the set programmes.

ELECTRONIC CLOCK (fig. 4.2)

The programmer is equipped with an electronic clock with lighted numbers which indicate hours and minutes.



Upon immediate connection of the oven or after a blackout, “12:00” will flash on the programmer panel.

To set the hour it is necessary to push the  button and then the **+** or **-** button until you have set the exact hour (fig. 4.2).

Alternatively, simultaneously push the   two buttons and then the **+** or **-** button.

Note: Setting the clock deletes any programme.

NORMAL COOKING WITHOUT THE USE OF THE PROGRAMMER

To manually use the oven, that is, without the aid of the programmer, it is necessary to cancel the flashing **AUTO** by pushing the button  (**AUTO** will be switched off and the symbol  will go on - fig. 4.3).

Attention: If the **AUTO** is not flashing (which means a cooking programme has already been inserted), by pushing the button  you have cancelled the programme and switched to manual.

The oven shall be switched off manually.

During a semi-automatic or automatic oven cooking program, once completed the programming procedure the oven lamp/s will be lit until the end of the cooking program. This means that, in case of delayed cooking start, the oven lamp/s will remain always lit.

In addition, if a fan assisted semi-automatic or automatic oven cooking program is set, further to the oven lamp/s also the oven fan motor (the motor inside the oven cavity) may be operating (together with the cooling fan motor) before the start of the cooking program; this is possible if the oven or cooktop has been used previously and the range is still hot/warm.



Fig. 4.1

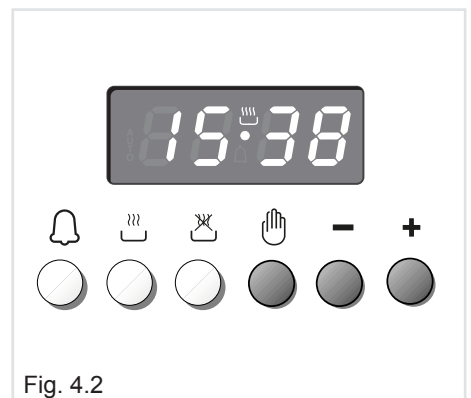

Fig. 4.2

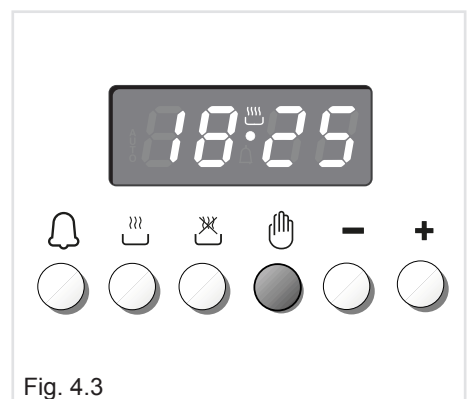





Fig. 4.3

ELECTRONIC TIMER

The timer programme consists only of a buzzer which may be set for a maximum period of 23 hours and 59 minutes.

If the **AUTO** is flashing push the  button.

To set the time, push the  button and the $+$ or $-$ until you obtain the desired time (fig. 4.4).

Having finished the setting, the normal time will appear on the panel and the  symbol will appear.

The countdown will start immediately and may be seen at any moment on the panel by simply pressing the button .

At the end of the time, the  symbol will be switched off and an intermittent buzzer will go off; this can be stopped by pressing any one of the buttons (not $+$ or $-$).

If the oven is switched on, you must switch off manually.

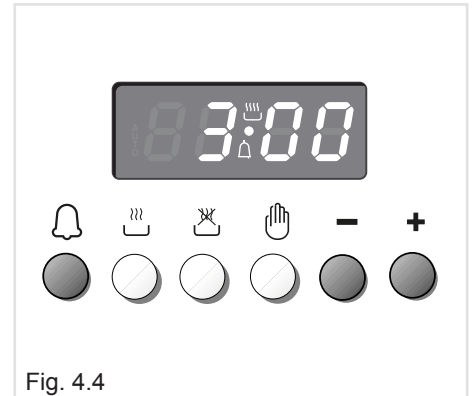

Fig. 4.4

SETTING THE FREQUENCY OF THE AUDIBLE SIGNAL

By pressing the $-$ button you can choose from three variations.

AUTOMATIC OVEN COOKING

To cook food automatically in the oven, it is necessary to:

1. Set the length of the cooking time
2. Set the end of the cooking time
3. Set the temperature and the oven cooking programme.

These operations are done in the following way:

1. Set the length of the cooking time by pushing the  button and the $+$ button to advance, or $-$ to go back if you have passed the desired time (fig. 4.5).

The **AUTO** and the  symbol will be on.

2. Set the end of the cooking time by pressing the  button (the cooking time already added to the clock time will appear), and the $+$ button (fig. 4.6); if you pass the desired time you may get back by pushing the $-$ button.

After this setting, the  symbol will go off. If after this setting, the **AUTO** flashes on the panel and a buzzer goes off, it means there was an error in the programming.

In this case, modify the end of cooking time or the cooking time itself by following the above instructions again.

3. Set the temperature and the cooking programme by using the switch and thermostat knobs of the oven (see specific chapters).

Now the oven is programmed and everything will work automatically, that is the oven will turn on at the right moment to end the cooking at the established time.

During cooking, the  symbol remains on.

By pushing the  button you can see the time that remains until the end of cooking.

At the end of the cooking time the oven will turn off automatically, the  symbol will turn off, **AUTO** will flash and a buzzer will sound, which can be turned off by pushing any of the buttons (not $+$ or $-$).

Turn the switch and thermostat knobs to zero and put the programmer onto "manual" by pressing the .

Attention: A power cut makes the clock go to zero and cancels the set programmes. After a powercut, "12:00" will flash on the panel.

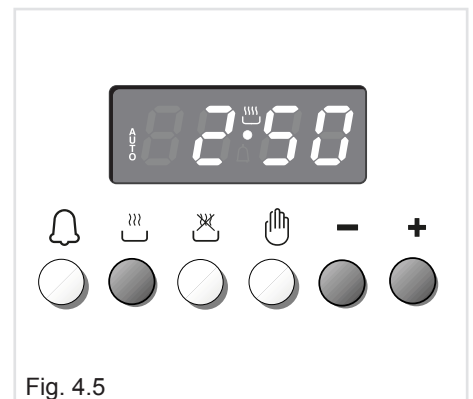

Fig. 4.5

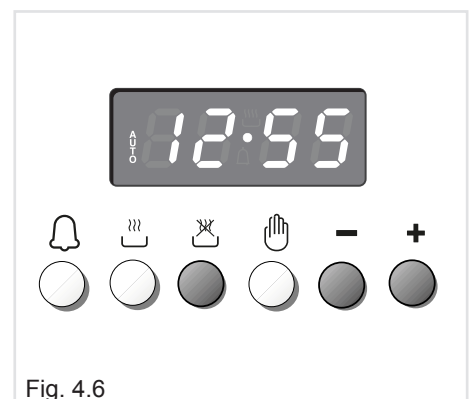





Fig. 4.6

The cooking program may be cancelled at any time by pushing .
In this case the oven shall be switched off manually.



SEMI-AUTOMATIC COOKING

This is used to automatically switch off the oven after the desired cooking time has elapsed.

There are two ways to set your oven:

1. Set the length of the cooking time by pushing the  button and the  button to advance, or  to go backwards if you have passed the desired time (fig. 4.7).



or



2. Set the end of the cooking time by pushing the  button and the  button to advance, or  to go backwards if you have passed the desired time (fig. 4.8).

AUTO and the  symbol will be on.

Then set the temperature and the cooking programme using the oven switch and thermostat knobs (see specific chapters).

The oven is switched on and it will be switched off automatically at the end of the desired time.

During cooking, the  symbol remains on and by pressing the button  you can see the time that remains till the end of the cooking.

At the end of cooking, the oven and the  symbol will turn off, the **AUTO** will flash and a buzzer will sound; that can be stopped by pushing any of the buttons (not  or ).

Turn the switch and thermostat knobs to zero and put the programmer onto "manual" by pressing the  button.

Attention: A power cut makes the clock go to zero and cancels the set programmes. After a powercut, "12:00" will flash on the panel.

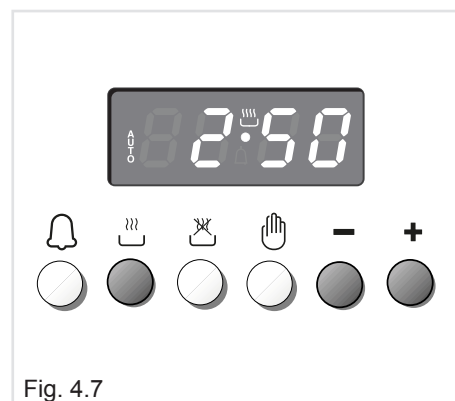

Fig. 4.7

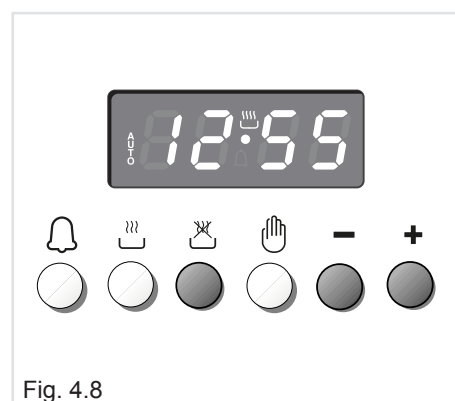



Fig. 4.8

The cooking program may be cancelled at any time by pushing .
In this case the oven shall be switched off manually.

WARNING VERY IMPORTANT

Before any operation of cleaning and maintenance disconnect the appliance from the electrical mains supply.

Do not use steam jet cleaners because the humidity could infiltrate into the appliance making it dangerous.

Do not use harsh abrasive cleaners or sharp metal scrapers to clean the oven door glass since they can scratch the surface, which may result in shattering of the glass.

WARNING !!



Do not store flammable material in the oven or in the storage drawer.

GENERAL RECOMANDATION

- **Important:** Before any operation of cleaning and maintenance disconnect the appliance from the electrical supply.
- It is advisable to clean when the appliance is cold and especially for cleaning the enamelled parts.
- Avoid leaving alkaline or acidic substances (lemon juice, vinegar, etc.) on the surfaces.
- Avoid using cleaning products with a chlorine or acidic base.
- **IMPORTANT:** The use of suitable protective clothing/gloves is recommended when cleaning and maintaining the appliance.
- **WARNING**
When correctly installed, your product meets all safety requirements laid down for this type of product category. However special care should be taken around the rear or the underneath of the appliance as these areas are not designed or intended to be touched and may contain sharp or rough edges, that may cause injury.

ENAMELLED PARTS

- All the enamelled parts must be cleaned with a sponge and soapy water only or other non-abrasive products.
- Dry preferably with a microfibre or soft cloth.
- Acidic substances like lemon juice, tomato sauce, vinegar etc. can damage the enamel if left too long.

PAINTED PARTS AND SILK-SCREEN PRINTED SURFACES

- Clean using an appropriate product. Always dry thoroughly.

IMPORTANT: these parts must be cleaned very carefully to avoid scratching and abrasion. You are advised to use a soft cloth and neutral soap.

STAINLESS STEEL ELEMENTS

- Stainless steel parts must be rinsed with water and dried with a soft and clean cloth.
- For difficult dirt, use a specific non-abrasive product available commercially or a little hot vinegar.

INSIDE OF OVEN

The oven should always be cleaned after use when it has cooled down.

The cavity should be cleaned using a mild detergent solution and warm water.

Suitable proprietary chemical cleaners may be used after first consulting with the manufacturers recommendations and testing a small sample of the oven cavity.

Abrasive cleaning agents or scouring pads/cloths should not be used on the cavity surface.

NOTE: The manufacturers of this appliance will accept no responsibility for damage caused by chemical or abrasive cleaning.

Let the oven cool down and pay special attention not to touch the hot heating elements inside the oven cavity.

VITROCERAMIC SURFACE

Before cleaning the cooktop, make sure that it is switched off.

Remove any encrustation using a special scraper which can be bought (fig. 5.1).

Remove dust using a damp cloth.

Detergents can be used as long as they are not abrasive or corrosive.

All residues of detergent must be eliminated with a damp cloth.

Keep all objects that could be melted by the heat away from the top: plastic objects, aluminium foil, sugar or sugary products.

If an object melts on the top, remove immediately (while the top is still hot) using a special scraper to avoid permanent damage to the pyroceram surface. Avoid using knives and pointed objects as they could damage the surface of the top.

Also avoid using abrasive sponges or wire wool which can permanently scratch the pyroceram surface.

ATTENTION: MOST IMPORTANT!

If cleaning the glass ceramic hob using a special scraper tool take extra care to avoid damaging to the seal at the edges of the glass ceramic surface.

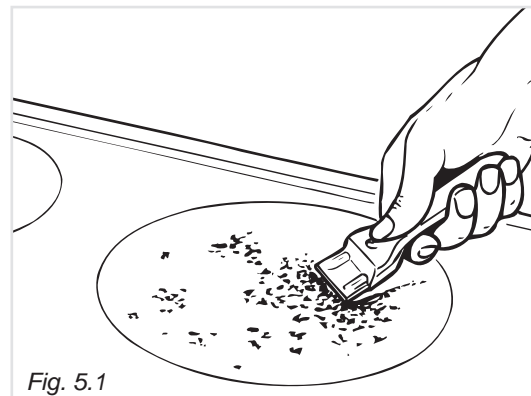

Fig. 5.1

OVEN FITTING OUT

- Assemble the wire racks to the oven walls using the 2 screws (fig. 5.2a).
- Slide the rack into the runners (fig. 5.2b).
The rack must be fitted so that the safety notch, which stops it sliding out, faces the inside of the oven; the guard rail shall be at the back.
- To dismantle, operate in reverse order.

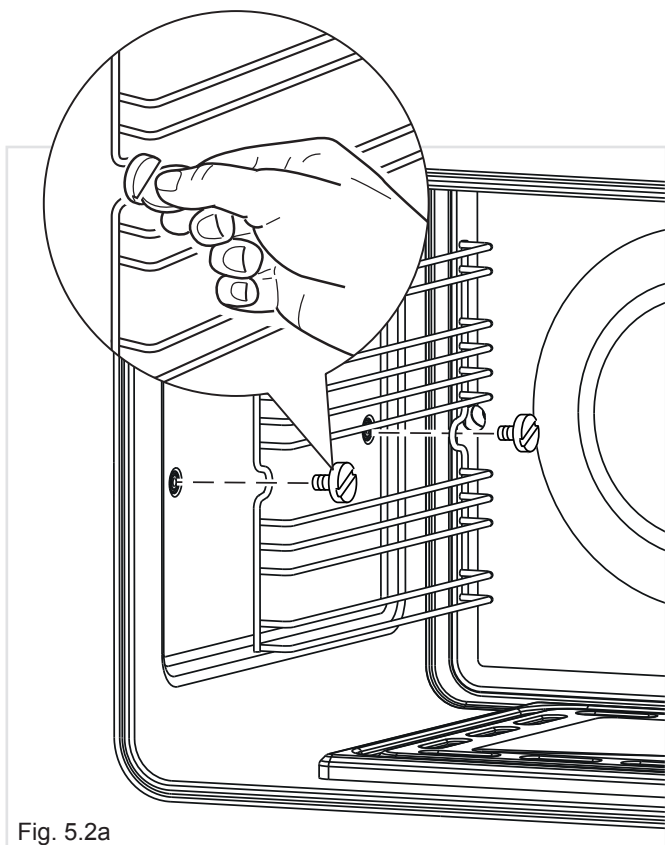

Fig. 5.2a

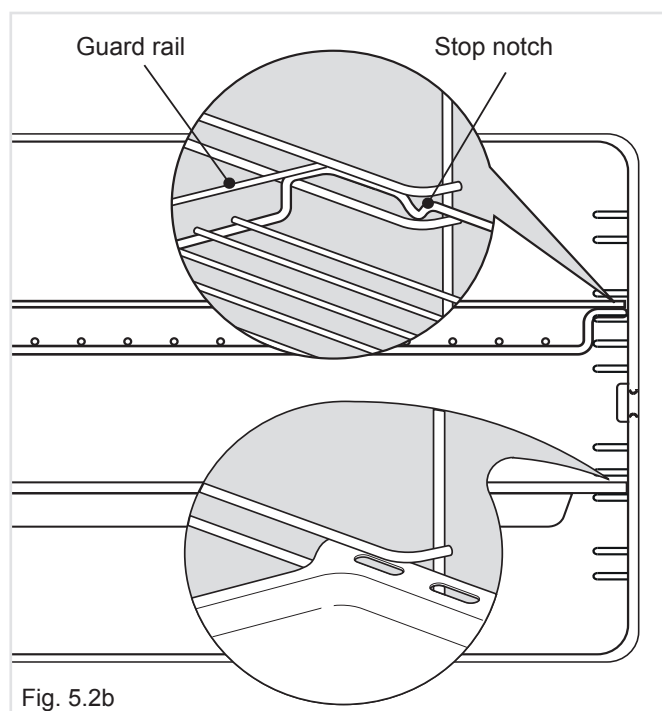

Fig. 5.2b

TELESCOPIC SLIDING SHELF SUPPORTS (SUPPLIED WITH SOME MODELS ONLY)

The telescopic sliding shelf supports make it safer and easier to insert and remove the oven shelves and trays. They stop when they are pulled out to the maximum position.

Important! When fitting the sliding shelf supports, make sure that you fit:

- The slides to the top wire of a rack. They do not fit on the lower wire.
- The slides so that they run out towards the oven door.
- Both sides of each pair of shelf slides.
- Both sides on the same level.

To fix the sliding shelf supports onto the side racks:

- Screw the side racks onto the oven wall (fig. 5.2a).
- Fit the sliding shelf supports onto the top wire of a rack and press (fig. 5.3). You will hear a click as the safety locks clip over the wire.

To remove the telescopic sliding shelf supports:

- Remove the side racks by unscrewing the fixing screws (fig. 5.2a).
- Lay down the sliding shelf support and side racks, with the telescopic sliding shelf support underneath.
- Find the safety locks. These are the tabs that clip over the wire of the side rack (arrow "1" in fig. 5.4).
- Pull the safety locks away from the wire to release the wire (arrow "2" in fig. 5.4).

Cleaning the sliding shelf supports:

- Wipe the supports with a damp cloth and a mild detergent only.
- Do not wash them in the dishwasher, immerse them in soapy water, or use oven cleaner on them.

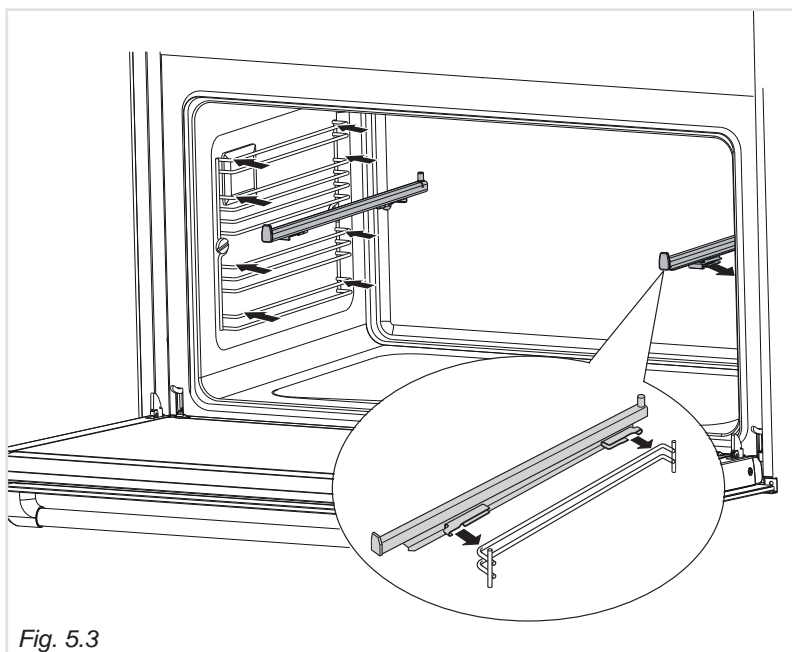

Fig. 5.3

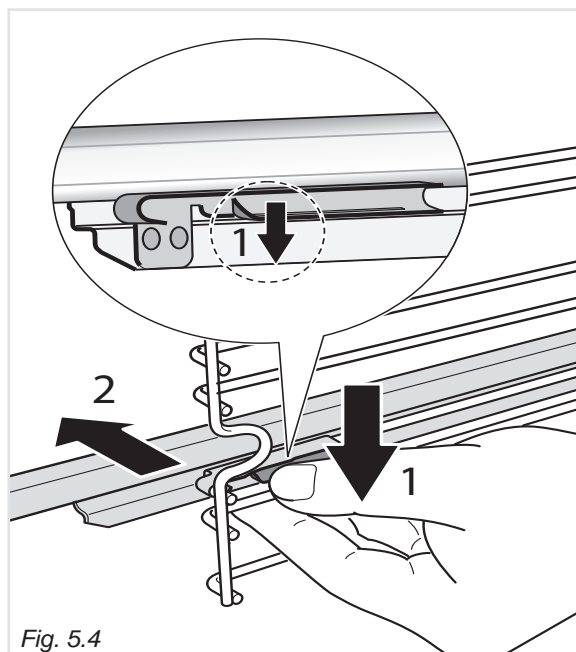

Fig. 5.4

REPLACING THE OVEN LIGHTS

(NOTE: DEPENDING ON YOUR MODEL, YOUR OVEN MAY ONLY HAVE SOME OF THESE LIGHTS)

WARNING: Ensure the appliance is switched off before replacing the lamp to avoid the possibility of electric shock.

- Let the oven cavity and the heating elements to cool down.
- Switch off the electrical supply.
- Remove the protective cover (figs. 5.5a - 5.5b).
- Replace the halogen lamp with a new one suitable for high temperatures having the following specifications: 120 V ac and same power (check watt power as stamped in the bulb itself) of the replaced lamp.
IMPORTANT WARNING: Never replace the lamp with bare hands; contamination from your fingers can cause premature failure. Always use a clean cloth or gloves.
- Refit the protective cover.

NOTE: Oven bulb replacement is not covered by your guarantee.

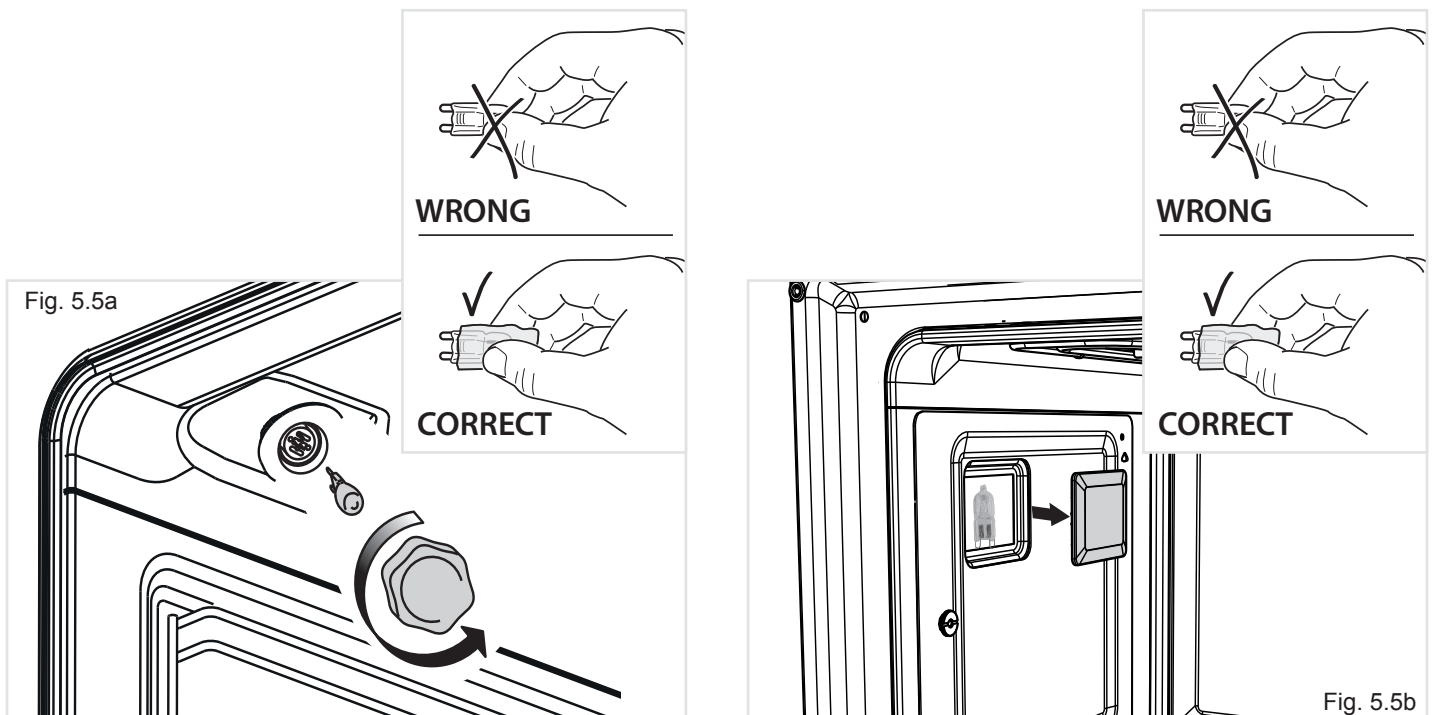

WARNING:

- Do not remove drawer while hot.
- Do not remove drawer during operation.
- Be sure drawer is empty before removing.

REMOVING THE STORAGE DRAWER

1. Open the drawer completely (fig. 5.6)
2. Move down the lever of left guide (fig. 5.7) and up the lever of right guide (fig. 5.8).
3. Remove the drawer; the levers have to be kept moved (fig. 5.6).

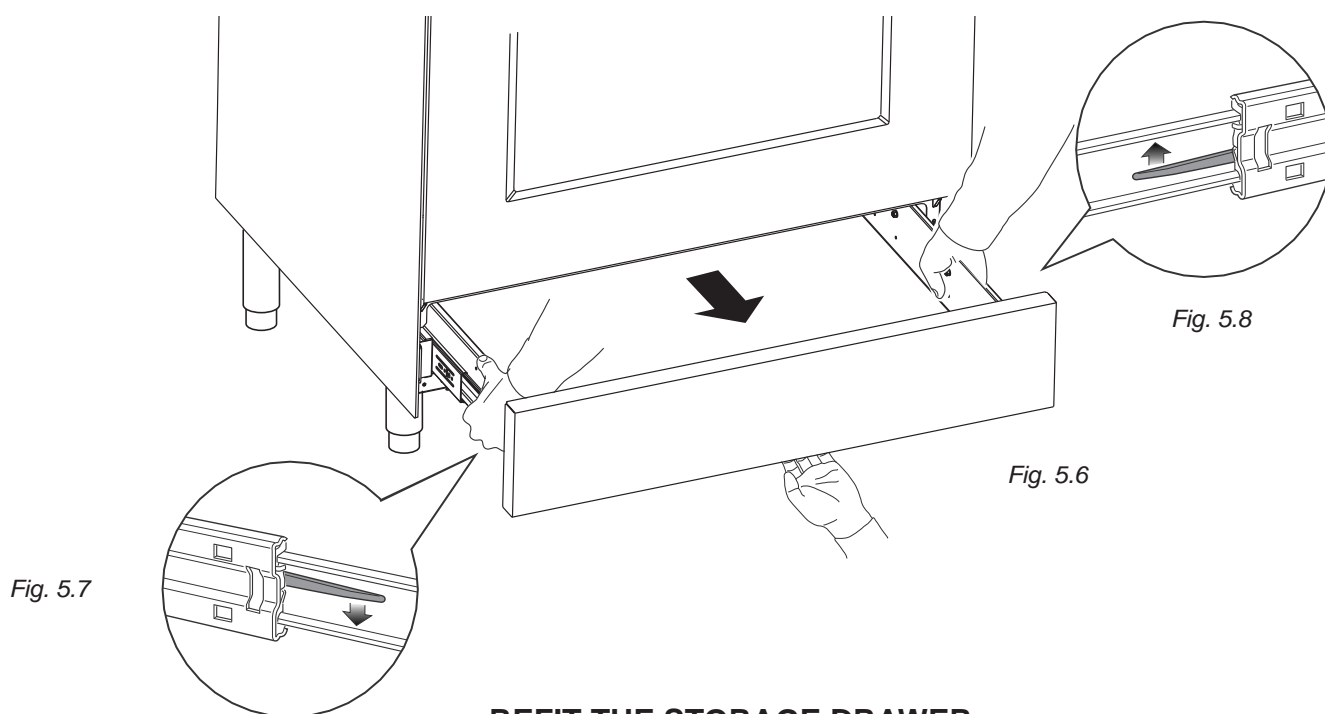
**REFIT THE STORAGE DRAWER**

1. Insert the drawer guides into the range guides (fig. 5.9)
2. Gently close the drawer completely; the safety catches will be automatically hooked.

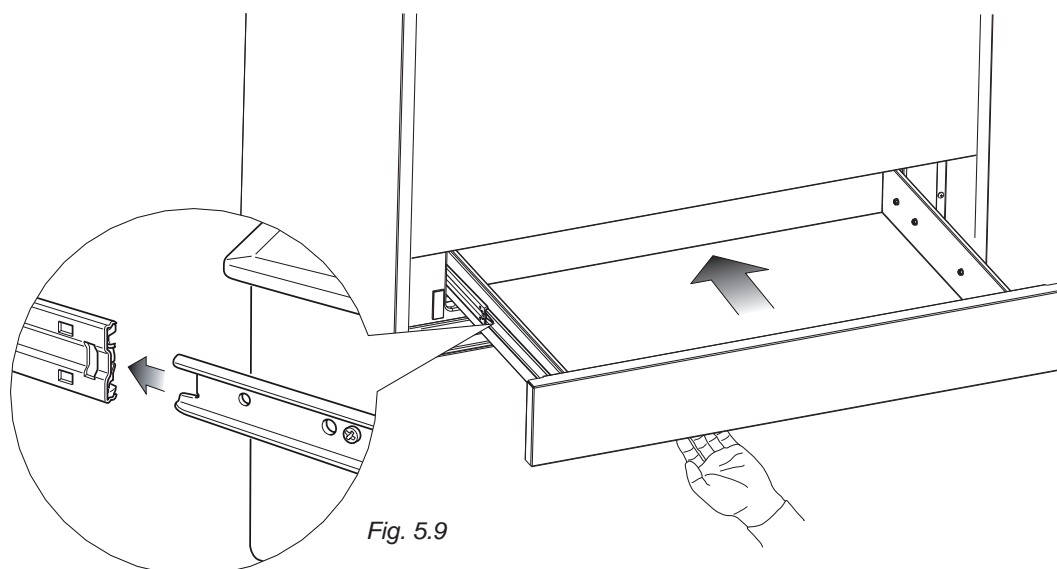

REMOVING THE OVEN DOOR

The oven door can easily be removed as follows:

- Open the door to the full extent (fig. 5.10).
- Open the lever "A" completely on the left and right hinges (fig. 5.11).
- Hold the door as shown in fig. 5.12.
- Gently close the door (fig. 5.12) until left and right hinge levers "A" are hooked to part "B" of the door (fig. 5.13).
- Withdraw the hinge hooks from their location following arrow "C" (fig. 5.14).
- Rest the door on a soft surface.

REFIT THE DOOR

1. Hold the door firmly (fig. 5.15).
2. Insert the hinge tongues into the slots, making sure that the groove drops into place as shown in the figure 5.16.
3. Open the door to its full extent.
4. Fully close the levers "A" on the left and right hinges, as shown in the figure 5.17.
5. Close the door and check that it is properly in place.

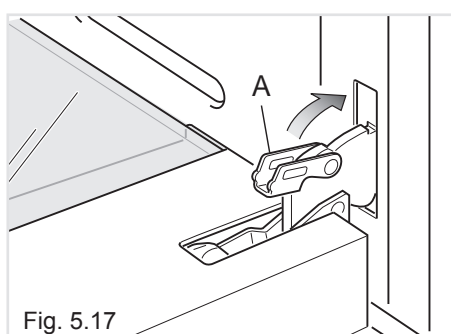
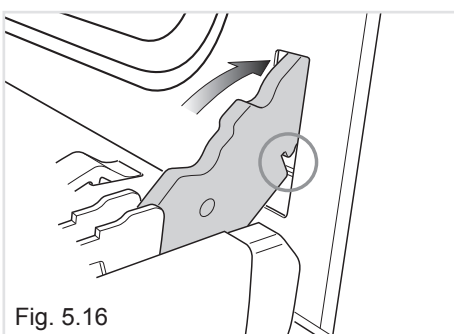
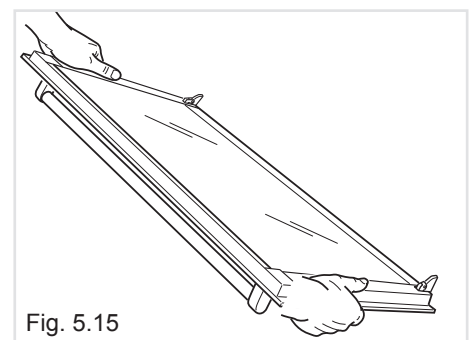
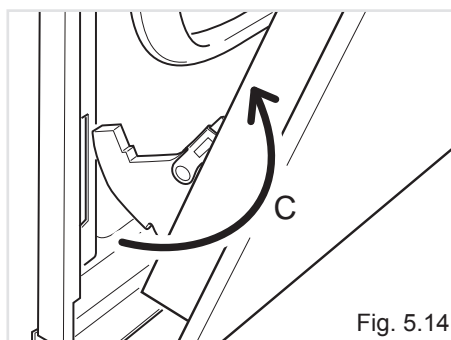
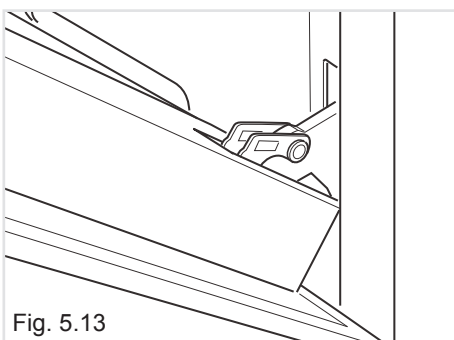
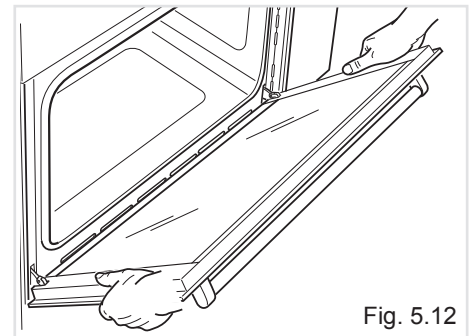
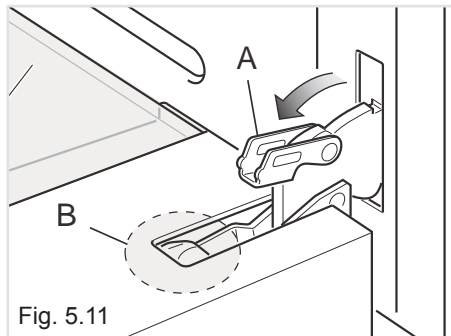
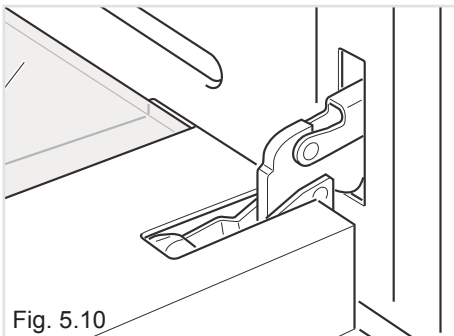

Important!

Always keep a safe distance from the door hinges, paying special attention to position of your hands.

If the door hinges are not correctly hooked, they could unhook and close suddenly and unexpectedly with risk of injury.



DO'S AND DO NOT'S

- Do always use the oven with the door closed.
- Do always broil with the door closed.
- Do read the user instructions carefully before using the range for first time.
- Do allow the oven to heat for about two hours, before using for the first time, in order to expel any smell from the new oven insulation, without the introduction of food. Make sure the kitchen is well ventilated during the conditioning.
- Do clean your oven regularly.
- Do remove spills as soon as they occur.
- Do always use oven gloves when removing food shelves and trays from the oven.
- Do not allow children near the range when in use.
- Do not allow fat or oils to build up in the oven base, or oven accessories.
- Do not place cooking utensils or plates directly onto the oven base.
- Do not place hot enamel parts in water. Leave them to cool first.
- Do not allow vinegar, coffee, milk, saltwater, lemon or tomato juice to remain in contact with enamel parts (i.e. inside the oven).
- Do not use abrasive cleaners or powders that will scratch the surface of the stainless steel and the enamel.
- Do not attempt to repair the internal workings of your range.
- Do remove the protective film before the first use.
- Fire risk! Do not store flammable material in the oven and in the storage compartment.
- Do not use the oven with the oven door open.
- Do not use the oven to warm or heat a room.
- Do not use the appliance if the ceramic glass surface is broken or damaged. If you note a crack on the cooktop, disconnect the appliance immediately from the electrical mains supply and call the After-Sales Service.
- Do not leave aluminium foil, greaseproof paper etc. or plastic on the hob when it is hot.
- Do not drop heavy or sharp objects on the glass ceramic cooktop.

FOR YOUR SAFETY

Under no circumstances should any external covers be removed for servicing or maintenance except by suitably qualified personnel

The manufacturer cannot be held responsible for possible inaccuracies due to printing or transcription errors in the present booklet.
The manufacturer reserves the right to make all modifications to its products deemed necessary for manufacture or commercial reasons at any moment and without prior notice, without jeopardising the essential functional and safety characteristics of the appliances.